

PHY301- Circuit Theory Mid Term Solved With References | By Masoom Fairy |

Phy301- Circuit Theory Solved Mid Term MCQS and Subjective with References.

Phy301-Mid Term Solved With References



By Masoom Fairy



Question No: 1 (Marks: 1) - Please choose one

If we connect 3 capacitors in series, the combined effect of all these capacitors will be

- ▶ equal to the sum of individual capacitors
- ▶ the sum of reciprocals of individual capacitors [Page 22](#)
- ▶ zero
- ▶ product of all

**PHY301- Circuit Theory Mid Term Solved
With References
|By Masoom Fairy|**

Question No: 2 (Marks: 1) - Please choose one

A node which emerges as a result of combination of two ordinary nodes is called

- ▶ Heavy node
- ▶ Simple node
- ▶ Super mes
- ▶ **Super node** Page 52

Question No: 3 (Marks: 1) - Please choose one

Unit of inductance is

- ▶ mho
- ▶ ohm
- ▶ **Henry** page 19
- ▶ Farad

Question No: 4 (Marks: 1) - Please choose one

Reciprocal of resistance is

- ▶ Conductance
- ▶ Inductance
- ▶ **Capacitance** Page 22
- ▶ Resistivity

Question No: 5 (Marks: 1) - Please choose one

An ideal voltage source is a circuit element where the voltage across it is independent of

- ▶ resistance
- ▶ **current** Page 26
- ▶ capacitance
- ▶ inductance

Question No: 6 (Marks: 1) - Please choose one

Sum of all currents entering in the node is equal to sum of currents leaving the node, is statement of

- ▶ Ohm's law
- ▶ **Kirchhoff's current law** LECTURE 7
- ▶ Jaime's law
- ▶ Rutherford's law

PHY301- Circuit Theory Mid Term Solved With References | By Masoom Fairy |

Question No: 7 (Please choose one)

Which current source will be used for super mesh?

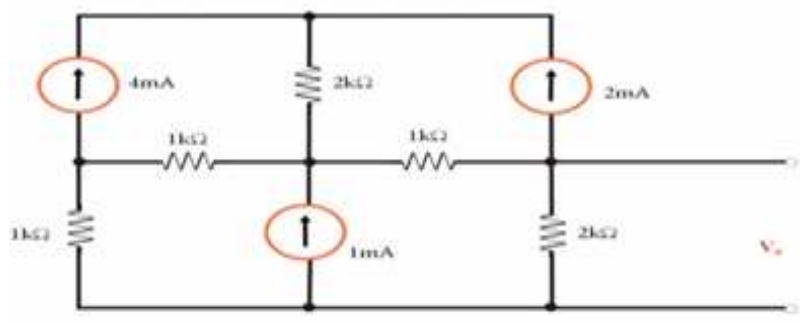

▶ 4mA

▶ 2mA

▶ **1mA** when two meshes share current source then it became super mesh

▶ 2mA and 4mA

Question No: 8 - Please choose one

How many KVL equations can be written for the given circuit?

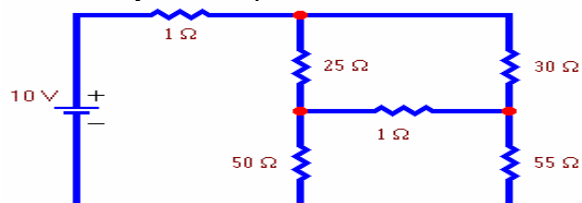

**PHY301- Circuit Theory Mid Term Solved
With References
| By Masoom Fairy |**

▶ 2

▶ 4

▶ 3 because 3 meshes or loops are formed and number of loops is equal to number of equations.

▶ 1

Question No: 9 - Please choose one

For the given circuit, voltage V_{DF} is

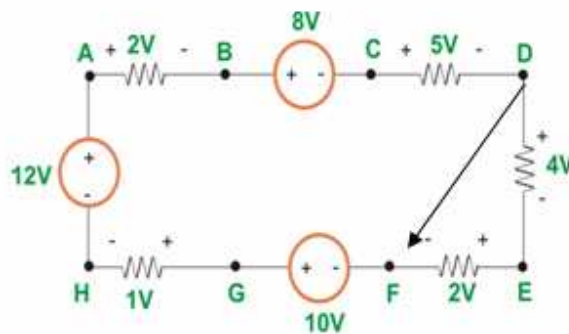

▶ 6v

▶ 2v

▶ 4v

▶ 10v

Question No: - Please choose one

If a parallel circuit is open in main line, the current

PHY301- Circuit Theory Mid Term Solved With References | By Masoom Fairy |

- ▶ increases in each branch
- ▶ is zero in all the branches
- ▶ is zero only in the branch that has highest resistance
- ▶ increases in the branch that has lowest resistance.

Question No: 11 - Please choose one

How many loop equations can be written for this circuit?

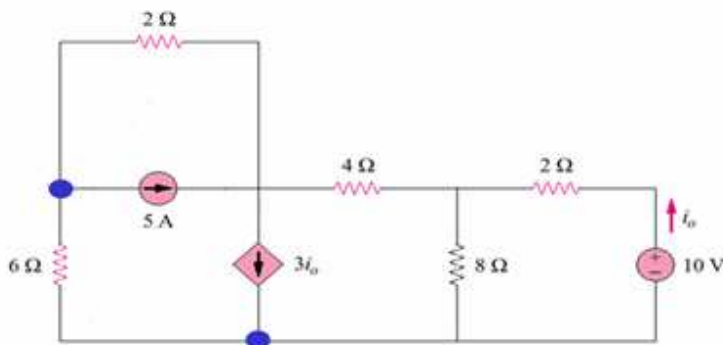

▶ 2

▶ 4

LOOP

It is the closed path for the flow of current in which no node is encountered more than once.

▶ 3

▶ 5

PHY301- Circuit Theory Mid Term Solved With References | By Masoom Fairy |

Question No: 12) – Please choose one

How many sources are dependent sources in given circuit?

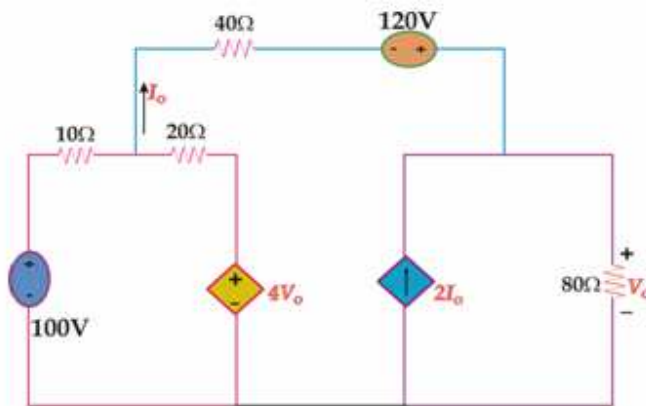

- ▶ 3
- ▶ 2
- ▶ 4
- ▶ 1

Question No: 13 - Please choose one

How many loops can be assigned to given figure?

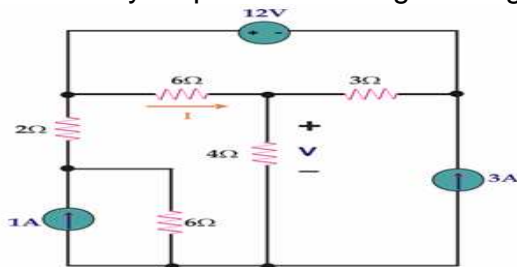

- ▶ 2

PHY301- Circuit Theory Mid Term Solved With References | By Masoom Fairy |

▶ 4

▶ 3

▶ 5

Question No: 14 - Please choose one

Through which resistance most current will flow

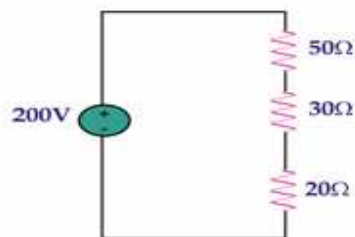

▶ 50Ω

▶ 30Ω

▶ 20Ω

▶ same through all resistance Because same current flowing through series combination. Page 32

Question No: 15 - Please choose one

In given circuit power dissipated across each bulb is 20w. What would be the resistance of each bulb.

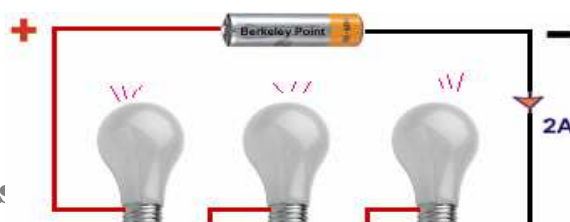

**PHY301- Circuit Theory Mid Term Solved
With References
|By Masoom Fairy|**

▶ 5Ω

$$\begin{aligned}P &= V \cdot I \\20 &= V \cdot 2A \\20/2 &= V \\V &= 10v \\ \text{So,} \\ R &= V/I = 10/2 = 5 \text{ ohm} = \text{Ans.....}\end{aligned}$$

▶ 10Ω

▶ 40Ω

▶ 20Ω

Question No: 16 - Please choose one

In the figure below Voltage drop across 7Ω will be

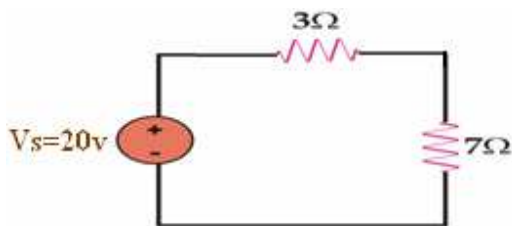

▶ 20v

▶ 14v

$$\begin{aligned}V &= R/RT \cdot V_S \\ \text{So,}\end{aligned}$$

**PHY301- Circuit Theory Mid Term Solved
With References
| By Masoom Fairy |**

$$V = \frac{7}{10} \times 20 = 14V$$

- ▶ 6v
- ▶ 10v

Question No: 17 - Please choose one

If current flowing through 4Ω is 1Ma , voltage drop across it will be

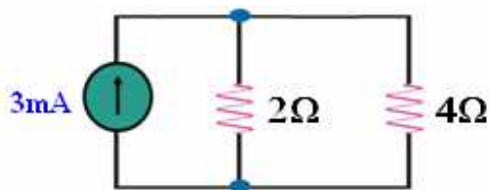

- ▶ 2V
- ▶ 6V
- ▶ 4V not sure
- ▶ 12V

Question No: 18 - Please choose one

For the given figure current flowing through 5Ω is

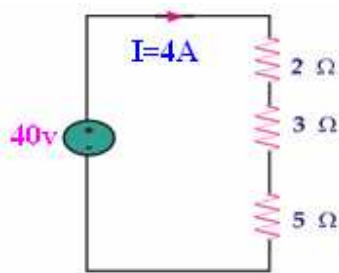

PHY301- Circuit Theory Mid Term Solved
With References
|By Masoom Fairy|

▶ 5A

▶ 4A same current will flow in series circuit.

▶ 10A

▶ 2A

Question No: 19 - Please choose one

The value of I_a for given circuit is

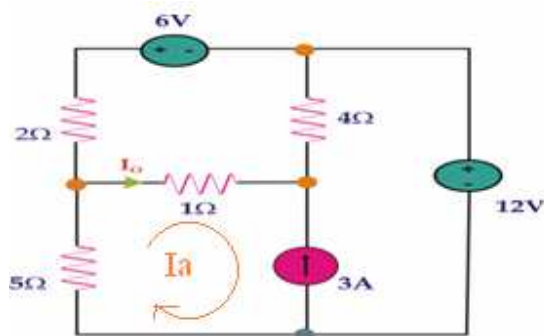

▶ $I_a = I_o$

▶ $I_a = 3A$

▶ $I_a = -3A$ Current is not in same direction with 3A.

▶ $I_a = 6v$

PHY301- Circuit Theory Mid Term Solved
With References
| By Masoom Fairy |

Question No: 20 - Please choose one

In the given circuit the value of independent current source is

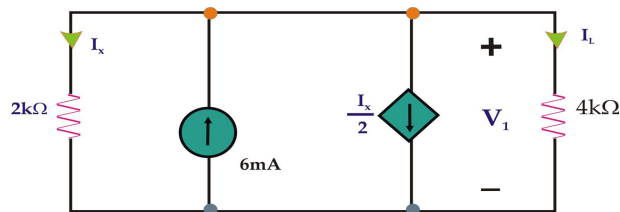

- ▶ I_x
- ▶ $I_x/2$ not sure
- ▶ 6Ma
- ▶ I_L

MID TERM EXAMINATION
SEMESTER Fall (2004)
PHY- 301 CIRCUIT THEORY

(a) When placed close together, a positively charged material and a negatively charged material will

- a) Repel
- b) Become neutral
- c) Attract Page 9
- d) Exchange charges

II) Potential difference is another term for

- a) Energy

**PHY301- Circuit Theory Mid Term Solved
With References
| By Masoom Fairy |**

b) Voltage Page 8

- c) Watt
- d) Distance of an electron from the nucleus.

III) There is no current in the circuit when

- a) A switch is closed
- b) A switch is open
- c) There is no voltage
- d) Answer (a) and (c)
- e) Answer (b) and (c)**

IV) How much resistance is required to limit the current from a 10V battery to 1Ma

- a) 100Ω
- b) $1.0\text{ k}\Omega$
- c) 10Ω

d) $10\text{k}\Omega$ $R=V/I$

So, $R=10/1=10\text{ ohm}$

V) Which of the following statements are true concerning the figure below

- a) R_1 and R_2 are in series with R_3 , R_4 , and R_5
- b) R_1 and R_2 are in series
- c) R_3 , R_4 , and R_5 are in parallel
- d) The series combination of R_1 and R_2 is in parallel with the series combination of R_3 , R_4 , and R_5 .

e) Answers (b) and (d)

**MID TERM EXAMINATION SEMESTER (Summer 2007) I
PHY- 301 CIRCUIT THEORY**

(b) Current divider is used when

- a) two or more resistances are in series to a voltage source
- b) two or more resistances are in parallel to a current source Sure**
- c) One resistance in parallel to current source
- d) None of above

**PHY301- Circuit Theory Mid Term Solved
With References
|By Masoom Fairy|**

II) 10Ω and 5Ω resistances are in series. If current through 5Ω is 5 ampere , current of 10Ω will be

- a) 10A
- b) 20A
- c) 5A Page 32 Current will be same.**
- d) 40

III) If the current arrow is directed into the + marked terminal of an element, then $p=vi$ yields the.....

- a) absorbed power Not sure**
- b) emitted power
- c) loss power
- d) high power

IV) When a proton and an electron come close together they

- a) repel each other
- b) become neutral
- c) have no effect
- d) attract each other Page 9**

V) The resistance of an open circuit is

- a) high**
- b) low
- c) zero
- d) infinite

VI) The current passing through the conductor is directly proportional to the voltage provided temperature remains constant, is the statement of

- a) Kirchhoff's law
- b) Newton's law
- c) Ohm's law Page 24**
- d) Pascal law

MIDTERM EXAMINATION

Fall 2009

PHY301- Circuit Theory

Question No: 1 (Marks: 1) – Please choose one

**PHY301- Circuit Theory Mid Term Solved
With References
|By Masoom Fairy|**

Which of the following statements is correct.

▶ **Neutrons and protons lie inside the nucleus.** Lecture 1 Page 4, 5, 6..

- ▶ Protons revolve around the nucleus.
- ▶ Neutron is +ve particle.
- ▶ Electron lies inside nucleus

Question No: 2 (Marks: 1) – Please choose one

Current through a short circuit is

- ▶ zero
- ▶ minimum
- ▶ **Maximum** Page 14 'Topic Short Circuit'.
- ▶ leakage current

Question No: 3 (Marks: 1) – Please choose one

When two resistances are connected in series

- ▶ They must both have same resistance value
- ▶ The voltage across each must be the same.
- ▶ They must have different resistance value.

**PHY301- Circuit Theory Mid Term Solved
With References
|By Masoom Fairy|**

▶ **There is only one path for current for both resistances** Sure

Question No: 4 (Marks: 1) – Please choose one

Using voltage divider in the figure below Voltage drop across 3Ω will be

PHY301- Circuit Theory Mid Term Solved With References | By Masoom Fairy |

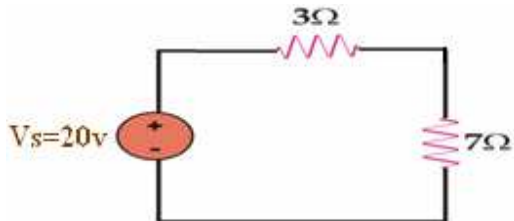

▶ 20v

▶ 14v

▶ 6v

$$V = \frac{R}{R_t} \cdot V_s \\ = \frac{3}{10} \cdot 20 = 6v = \text{Answer}$$

▶ 7v

Question No: 5 (Marks: 1) – Please choose one

In the given series fig. the total voltage of circuit is

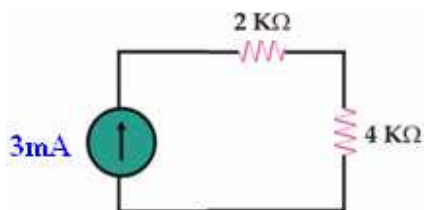

▶ 6V

▶ 12V

▶ 18V

**PHY301- Circuit Theory Mid Term Solved
With References
|By Masoom Fairy|**

$$\begin{aligned} V &= IR \\ &= 3\text{Ma} * 4+2 = 3\text{Ma} * 6 \\ &= 18\text{V} = \text{Ans....} \end{aligned}$$

► 10V

Question No: 6 (Marks: 1) – Please choose one

In given circuit power dissipated across each bulb is 20w. What would be the resistance of each bulb.

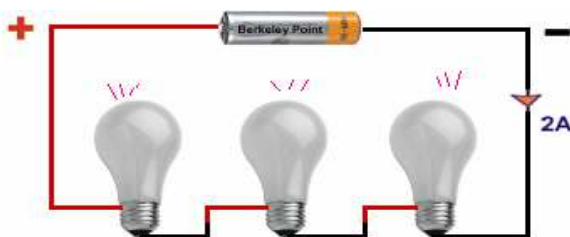

$$\begin{aligned} \text{► } 5\Omega \quad P &= V * I \\ 20 &= V * 2\text{A} \\ 20/2 &= V \\ V &= 10\text{v} \\ \text{So,} \\ R &= V/I = 10/2 = 5 \text{ ohm} = \text{Ans.....} \end{aligned}$$

► 10 Ω

► 40 Ω

► 20 Ω

MID TERM FALL Winter 2012.

**PHY301- Circuit Theory Mid Term Solved
With References
|By Masoom Fairy|**

**Total Questions: 26:
20 MCQS & 6 Subjective Questions:**

Question No: 1 - Please choose one

How many KVL equations can be written for the given circuit?

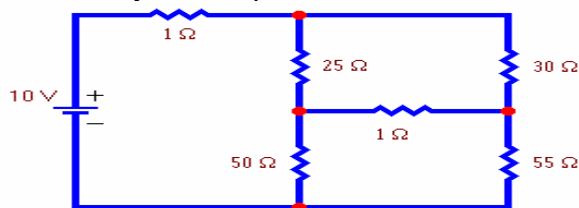

▶ 2

▶ 4

▶ 3 because 3 meshes or loops are formed and number of loops is equal to number of equations.

▶ 1

Question No: 2 - Please choose one

PHY301- Circuit Theory Mid Term Solved With References | By Masoom Fairy |

For the given circuit, voltage V_{DF} is

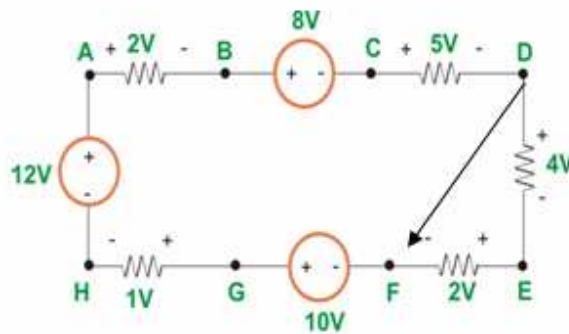

▶ **6v** $-2-4=0$
So, $V_{df}= 6$ Answer

- ▶ 2v
- ▶ 4v
- ▶ 10v

Question No: 3 – Please choose one

How many sources are dependent sources in given circuit?

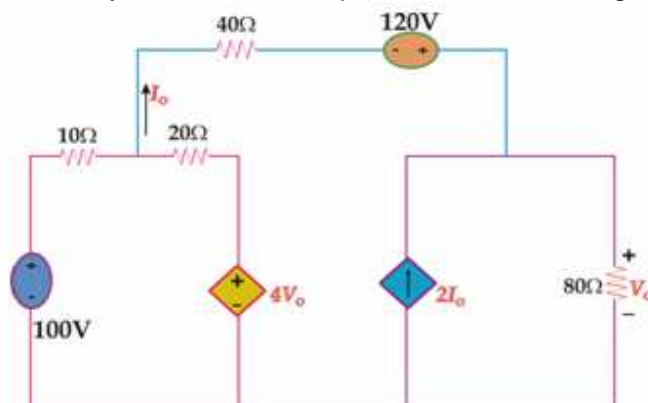

**PHY301- Circuit Theory Mid Term Solved
With References
|By Masoom Fairy|**

▶ 3

▶ 2

▶ 4

▶ 1

Question No: 4 - Please choose one

Through which resistance most current will flow

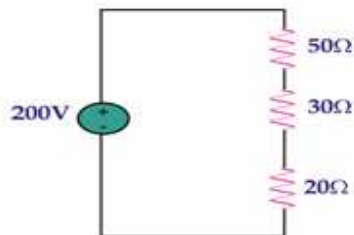

▶ 50Ω

▶ 30Ω

▶ 20Ω

▶ same through all resistance Because same current flowing through series combination. Page 32

Question No: 5 - Please choose one

In the figure below Voltage drop across 7Ω will be

PHY301- Circuit Theory Mid Term Solved
With References
|By Masoom Fairy|

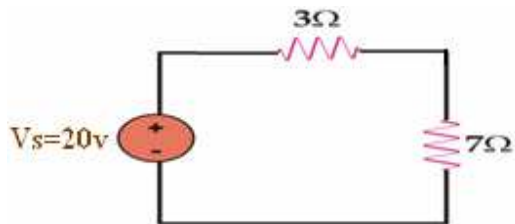

▶ 20v

▶ 14v

$$V = R/RT * VS$$

So,

$$V = 7/10 * 20 = 14V$$

▶ 6v

▶ 10v

Question No: 6 - Please choose one

If current flowing through 4Ω is 1mA, voltage drop across it will be

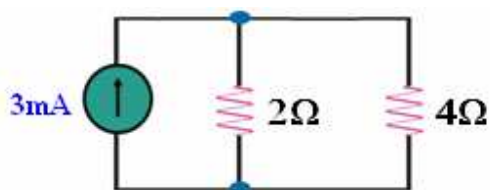

▶ 2V

▶ 6V

▶ 4V

**PHY301- Circuit Theory Mid Term Solved
With References
|By Masoom Fairy|**

▶ **12V** $V=IR \Rightarrow \frac{1}{4}=4$ So, $V=R/Rt*Vt \Rightarrow 4/1.33*4=12v=$ Answer.

Question No: 7 - Please choose one

For the given figure current flowing through 5Ω is

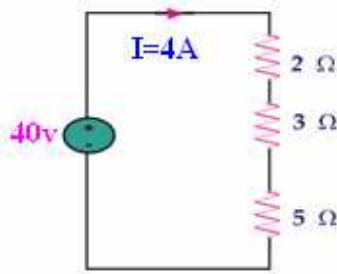

▶ 5A

▶ **4A** same current will flow in series circuit.

▶ 10A

▶ 2A

Question No: 8 - Please choose one

If an atom has 8 electrons in its outer-most shell then the Valence of this atom is:

▶ 1

▶ **Zero**

▶ 8

▶ 5

Question No: 9 - Please choose one

The value of I_a for given circuit is

PHY301- Circuit Theory Mid Term Solved
With References
|By Masoom Fairy|

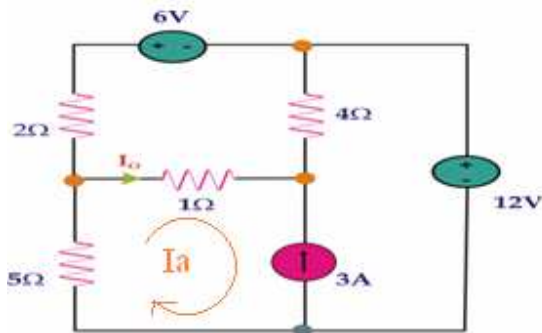

- ▶ $I_a = I_o$
- ▶ $I_a = 3A$
- ▶ $I_a = -3A$ Current is not in same direction with 3A.
- ▶ $I_a = 6v$

Question No: 10 (Marks: 1) – Please choose one

Using voltage divider in the figure below Voltage drop across 7Ω will be

PHY301- Circuit Theory Mid Term Solved
With References
|By Masoom Fairy|

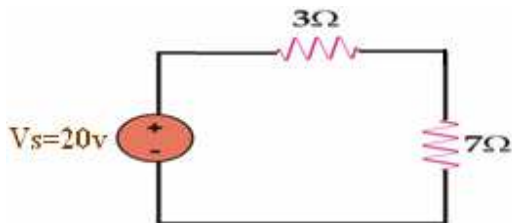

- ▶ 20v
- ▶ 14v $7/10 * 20 = 14 = \text{Answer.}$
- ▶ 6v
- ▶ 7v

Question No: 7 (Marks: 2)

What is the unit of capacitance and Inductance?

Answer:

The SI unit of capacitance is the farad; 1 farad = 1 coulomb per volt.
The unit of inductance is the henry (H) named after American scientist and magnetic researcher Joseph Henry. 1 H = 1 Wb/A

Question No: 8 (Marks: 2)

Define KIRCHHOFF'S VOLTAGE LAW (KVL):

Answer:

Kirchhoff's Voltage Law (or Kirchhoff's Loop Rule) is a result of the electrostatic field being conservative. It states that "the total voltage

PHY301- Circuit Theory Mid Term Solved With References |By Masoom Fairy|

around a closed loop must be zero". If this were not the case, then when we travel around a closed loop, the voltages would be indefinite. So, $\sum V=0$

Question No: 9 (Marks: 3)

Draw and label loop currents for circuit.write kvl for any one loop equation.

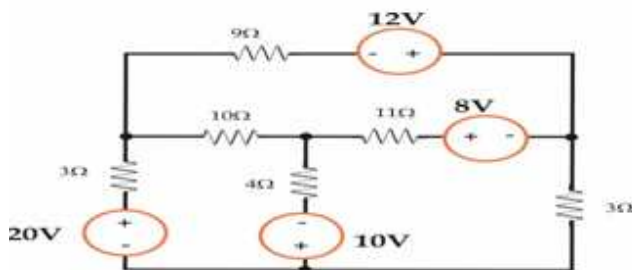

Solution:

Circuit will be redrawn as

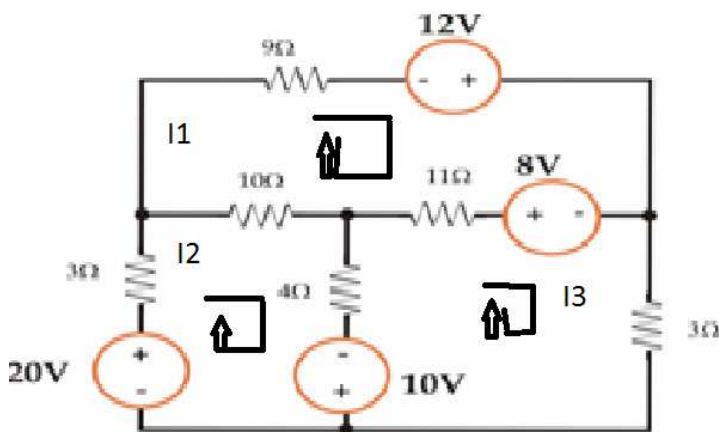

KVL for loop 1 is

PHY301- Circuit Theory Mid Term Solved With References | By Masoom Fairy |

$$9I_1 + I_2 + 8 + 11(I_1 - I_3) + 10(I_1 - I_2) + 9I_1$$

Question No: 10 (Marks: 5)

You are given the circuit Use Current Division Rule directly to find I_{30} .

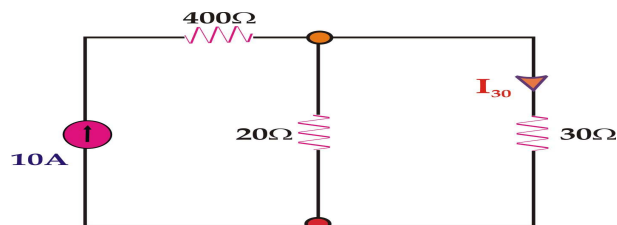

Solution:

Formula is

$$I_1 = R_2 / (R_1 + R_2)$$

AS we see that 30 ohm is in parallel with 20 ohm, So the resistance will become 12 ohm..

Now,

U sin g formula, we have

$$\begin{aligned} I_{30} &= \frac{400}{400 + 12} \times 10 \\ &= \frac{4000}{412} \\ &= 9.7A \end{aligned}$$

Question No: 11 (Marks: 5)

Determine the value **I4** for the given network.

**PHY301- Circuit Theory Mid Term Solved
With References
| By Masoom Fairy |**

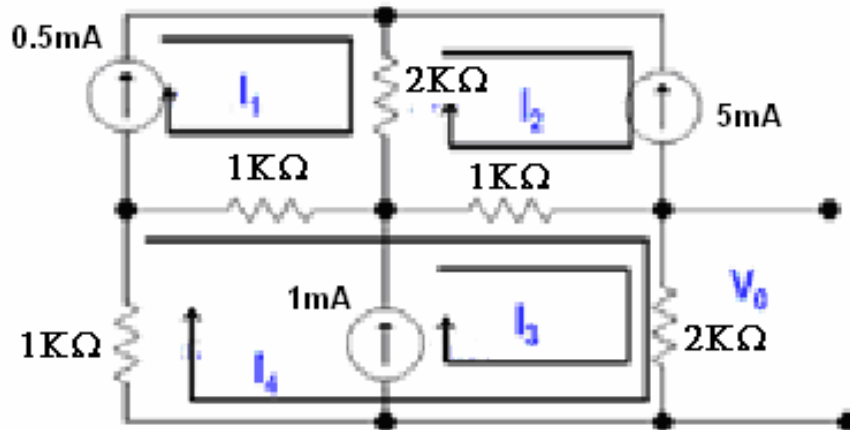

Solution:

$$I_1 = 0.5mA,$$

$$I_2 = -5mA,$$

$$I_3 = 1mA$$

FOR I_4

$$1k(I_4 - I_1) + 1k(I_4 - I_2) + 1kI_3 + 2kI_3 + 1kI_4 = 0$$

$$= 2kI_4 - 1kI_2 + 3kI_3 = 0$$

PUTTING I VALUES

$$= 2kI_4 - 5 + 3 = 0$$

$$= 2kI_4 - 2 = 0$$

$$= I_4 = \frac{2}{2} = 1mA...$$

Question No: 12 (Marks: 10)

If 1.76A current is flowing through circuit

Calculate the power dissipated by R_1 , R_2 , R_3 and R_4 . Determine the power delivered by the source, Write each step of the calculation to get maximum marks and also mention the units of each derived value.

PHY301- Circuit Theory Mid Term Solved
With References
| By Masoom Fairy |

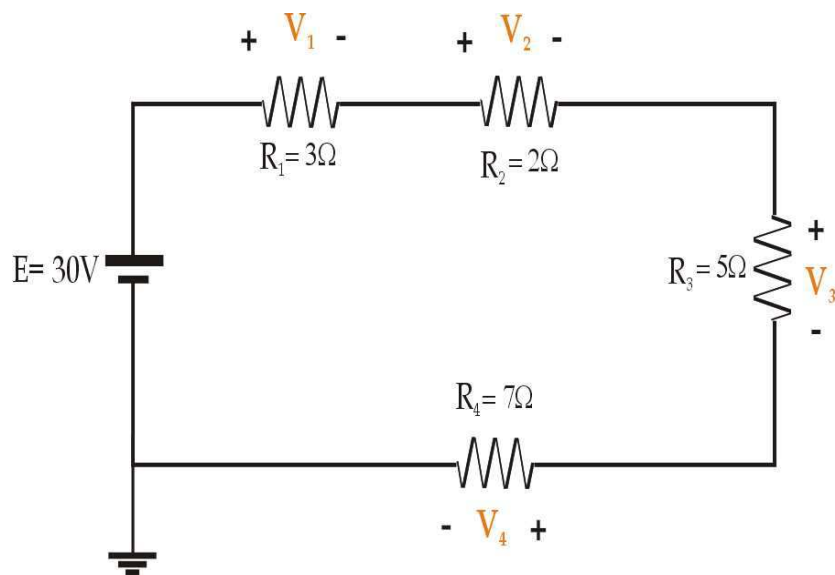

Solution:

$I = 1.76 \text{ A}$

As the formula for power delivered by source is

$$P = \frac{V^2}{R}$$

So,

$$P = \frac{30^2}{17} = \frac{900}{17}$$

$$P = 52.94 \text{ Watts}$$

Now Power dissipated in each resistor will:

**PHY301- Circuit Theory Mid Term Solved
With References
|By Masoom Fairy|**

$$P = I^2 R$$

$$P_1 = (1.76)^2 \times 3$$

$$P_1 = 9.2 \text{ watts}$$

$$P_2 = (1.76)^2 \times 2$$

$$= 6.19 \text{ watts}$$

$$P_3 = (1.76)^2 \times 5$$

$$= 15.48 \text{ watts}$$

$$P_4 = (1.76)^2 \times 7$$

$$= 21.68 \text{ watts}$$

**MID TERM EXAMINATION
SEMESTER Fall (2004)|
PHY- 301 CIRCUIT THEORY**

Question:

Use nodal analysis to find I_o in the given network.. Identify and label each node otherwise you will lose your marks. Label circuit diagram properly.

PHY301- Circuit Theory Mid Term Solved
With References
| By Masoom Fairy |

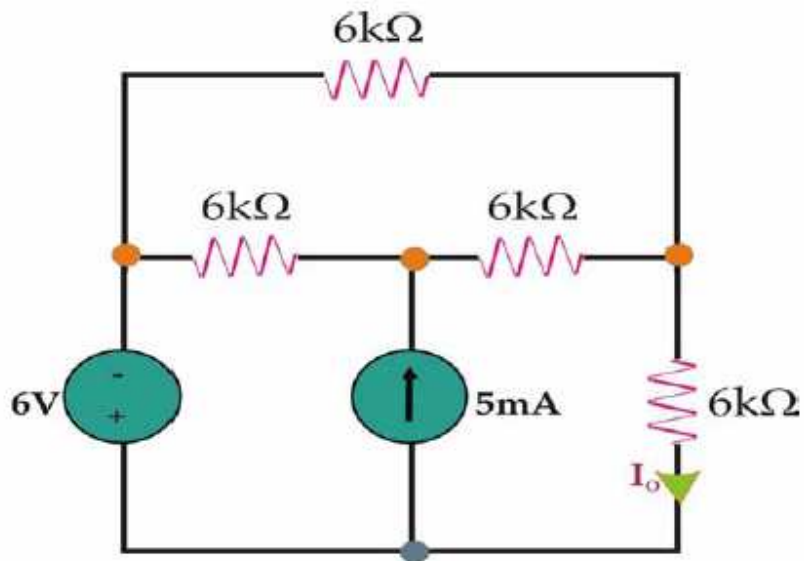

Answer/Solution

We will redraw figure as

**PHY301- Circuit Theory Mid Term Solved
With References
| By Masoom Fairy |**

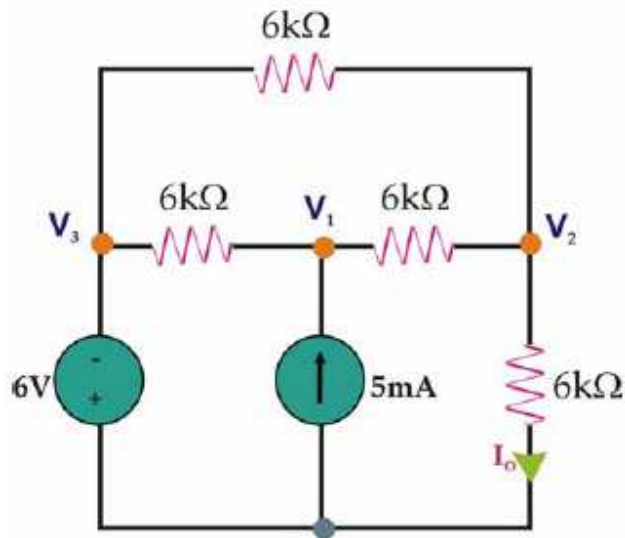

At Node 3

$$V_3 = -6V$$

KCL at Node 1

$$(V_1 + 6)/6 + (V_1 - V_2)/6 = -5\text{mA} \text{ ----- (A)}$$

KCL at Node 2

$$(V_2 + 6)/6 + (V_2 - V_1)/6 + V_2/6 = 0 \text{ ----- (B)}$$

Solving (A) and (B) we get

$$V_2 = 12/5 = 2.4$$

$$\text{Now } I_o = V_2/R = 2.4/6 = .4 \text{ Ma}$$

QUESTION:

Use Mesh analysis to find currents through all Meshes. Identify and label each mesh otherwise you will lose your marks. Label circuit diagram properly.

PHY301- Circuit Theory Mid Term Solved
With References
| By Masoom Fairy |

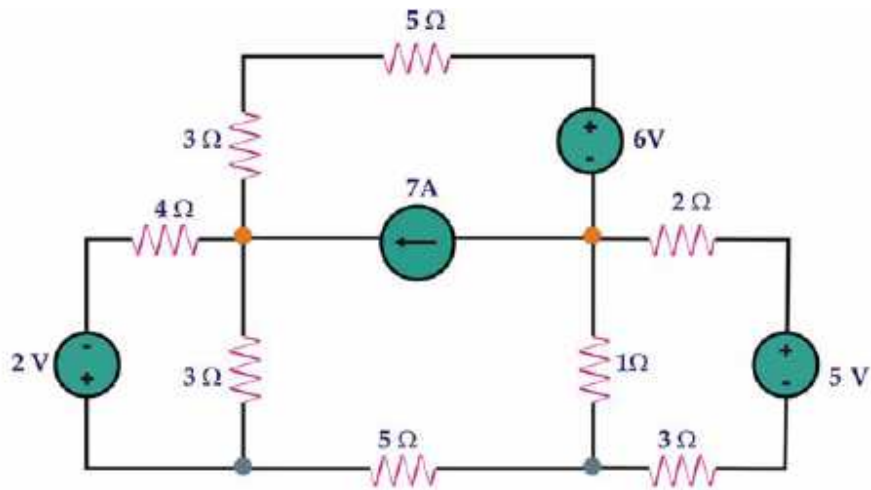

Solution:

We will redraw figure as:

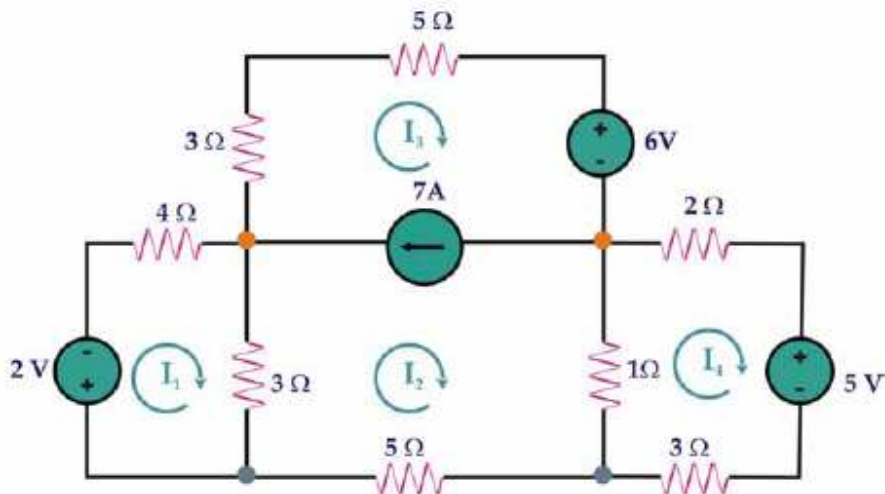

KVL equation for mesh 1

$$2 + 4I_1 + 3(I_1 - I_2) = 0$$

$$7I_1 - 3I_2 = -2 \text{ ----- (1)}$$

Now we will redraw figure for super mesh as

**PHY301- Circuit Theory Mid Term Solved
With References
| By Masoom Fairy |**

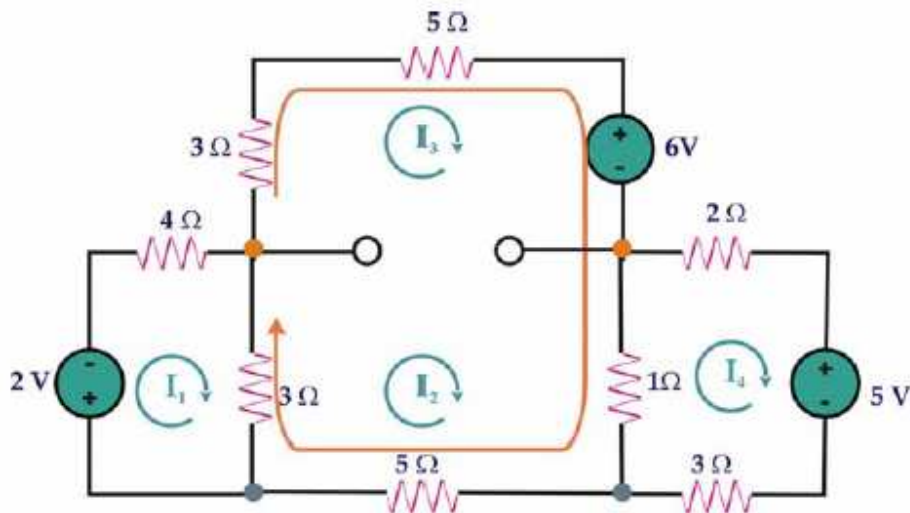

KVL equation for super mesh

$$1(I_2 - I_4) + 8I_3 + 5I_2 + 6 + 3(I_2 - I_1) = 0$$

Simplifying above equation we get

$$-3I_1 + 9I_2 + 8I_3 - I_4 = -6 \dots \dots \dots (2)$$

KVL equation for Mesh 4

$$2I_4 + 5 + 3I_4 + 1(I_4 - I_2) = 0$$

Simplifying we get

$$-I_2 + 6I_4 = -5 \dots \dots \dots (3)$$

Constraint Equation

$$I_3 - I_2 = 7 \dots \dots \dots (4)$$

From Equation (1)

$$I_1 = (3I_2 - 2)/7$$

From Equation (3)

$$I_4 = (I_2 - 5)/6$$

From Equation (4)

$$I_3 = I_2 + 7$$

Putting the values of I_1 , I_3 , I_4 in equation (2) & simplifying we get

$$653I_2 = -2176$$

$$I_2 = -3.33A$$

**PHY301- Circuit Theory Mid Term Solved
With References
| By Masoom Fairy |**

**$I_1 = - 1.71A$
 $I_3 = 3.67A$
 $I_4 = -1.38A$**

QUESTION:

Find the power absorbed by the $30k\Omega$ resistor in the circuit below.

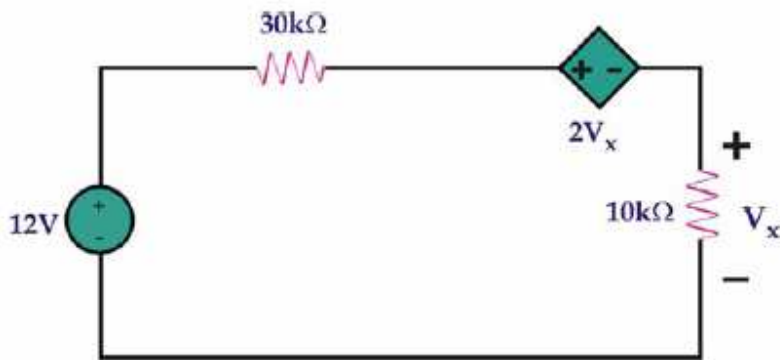

Solution:

Writing KVL equation

$$-12 - 30I + 2V_x + V_x = 0$$

$$-12 + 30KI + 20KI + 10KI = 0$$

$$I = 200\mu A$$

Therefore

$$P_{30k} = I^2 R$$

$$= (200 \times 10^{-6})^2 \times 30$$

$$= 1.2MW$$

QUESTION:

- Two resistors R_1 and R_2 of 5Ω each and R_3 of 10Ω are in series. How much is R_T . If we applied $80V$ source across the series string, how much is the current in R_3 .
- Define Potential difference. What is Conventional Current?

**PHY301- Circuit Theory Mid Term Solved
With References
|By Masoom Fairy|**

Answer/Solution:

(d) Two resistors R1 and R2 of 5Ω each and R3 of 10 Ω are in series. How much is RT. If we applied 80 V source across the series string, how much is the current in R3.

$$RT = R1+R2+R3 = 5+5+10 = 20\Omega \quad I = VT/RT = 80/ 20 = 4A$$

Answer:

(e) Define Potential difference. What is Conventional Current?

Potential difference The potential difference is defined as the amount of work per charge needed to move electric charge from the second point to the first, or equivalently, the amount of work that unit charge flowing from the first point to the second can perform. In the SI system of units, potential difference, electrical potential and electromotive force are measured in volts, leading to the commonly used term voltage and the symbol V. **OR Current** flowing in a conductor is due to a potential difference between its ends. Electrons move from a point of less positive potential to more positive potential and the current flows in the opposite direction. The SI unit of potential difference is the volt (V). Volts are the measure of Potential Difference across circuit elements (battery, resistor etc.). **Conventional Current** The motion of positive charge, in the opposite direction from electron flow, is considered as conventional current. Electricity was known of long before Benjamin Franklin. It was not understood very well, but it was known of. Scientists knew there were two kinds of electric charge. They knew there was electric current. Scientists believed that the opposite charges moved similarly in opposite directions. They defined one as positive and one as negative. They defined current to be in the direction of the positive charges. Later, they learned of their mistake. Only the negative charges move freely in conductors. Electrons had been defined as the negative charges. Current had been defined “backwards”. It was too late to redefine all of electrical physics, so the inconvenience holds to this day. The direction that the electrons move is opposite the direction that current points. Because of how electricity works, it isn't much of a

**PHY301- Circuit Theory Mid Term Solved
With References
|By Masoom Fairy|**

problem. Negative charge moving to the left through a wire has the same effect as positive charge moving to the right. So long as the total charge in the wire (protons and electrons) remains balanced, no trouble occurs.

Question: Marks: 2:

An electric heater takes 15A from the 120-V power line. Calculate the amount of power used also mention the units of derived value.

Solution:

$$P=VI$$

So,

$$P = 120 \times 15 = 1800 = \text{Answer}$$

**MID TERM EXAMINATION SEMESTER (Summer 2007) I
PHY- 301 CIRCUIT THEORY**

Question:

Why does a person wearing rubber shoes do not get electric shock when touching a naked conducting wire.

Marks=3

Answer:

Rubber is a bad conductor of electricity (it used to be used to insulate wires), but a moderate conductor of heat. Experiment: cover the outside of a soup can with rubber bands, and place it inside a slightly larger can. Put a known amount of ice inside the soup can and see how long it takes to melt. Remove the rubber bands and try it again. Other substances (newspaper, aluminum foil, cardboard) can be used also for comparison.

PHY301- Circuit Theory Mid Term Solved
With References
| By Masoom Fairy |

MID TERM FALL Winter 2012.

Subjective Paper:

Question: 21: What will be the V(not) of 20 Ohm Resistance?

Marks: 2:

Answer: $I_2 = -4A$, $V=IR$ so, $-4A * 20 = -80 = \text{Answer}$.

Question: 22: Calculate the voltages V_{ae} .

Marks: 2:

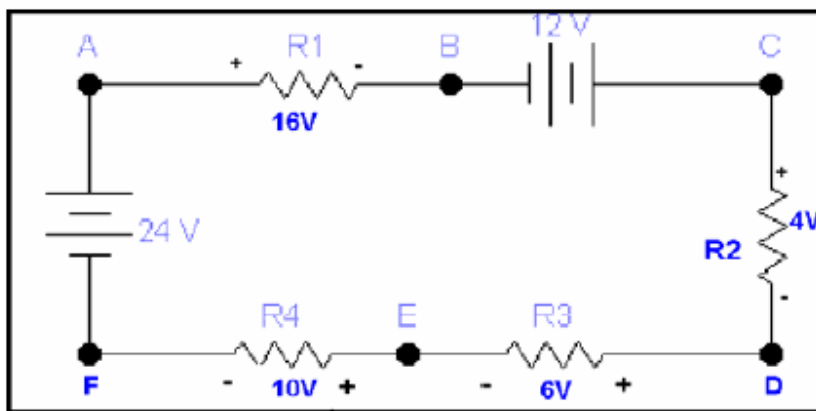

Answer:

For path AEFA

$$V_{AE} + 10 - 24 = 0 \text{ ----- (A)}$$

$$V_{AE} = 14 \text{ volt}$$

Question: 23: Calculate the voltage V_{ad} .

Marks: 3:

PHY301- Circuit Theory Mid Term Solved
With References
|By Masoom Fairy|

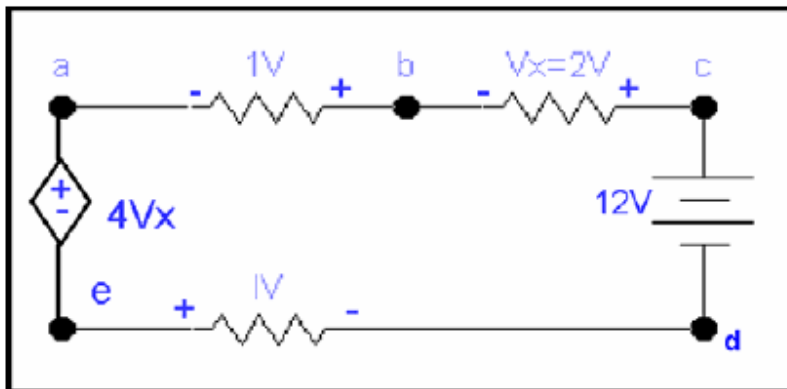

Answer:

For Vad

There are two paths in which Vad is the only unknown quantity they are adea and adcba.

For path adea the KVL equation will be

Vad

$$-1V - 4Vx = 0$$

where $Vx=2V$

V

ad

$$-1 - 8 = 0$$

$$Vad = 9 \text{ volts}$$

Question: 26: Use KVL labels each Mesh, write only Equation for Super Mesh. Marks: 5:

PHY301- Circuit Theory Mid Term Solved
With References
| By Masoom Fairy |

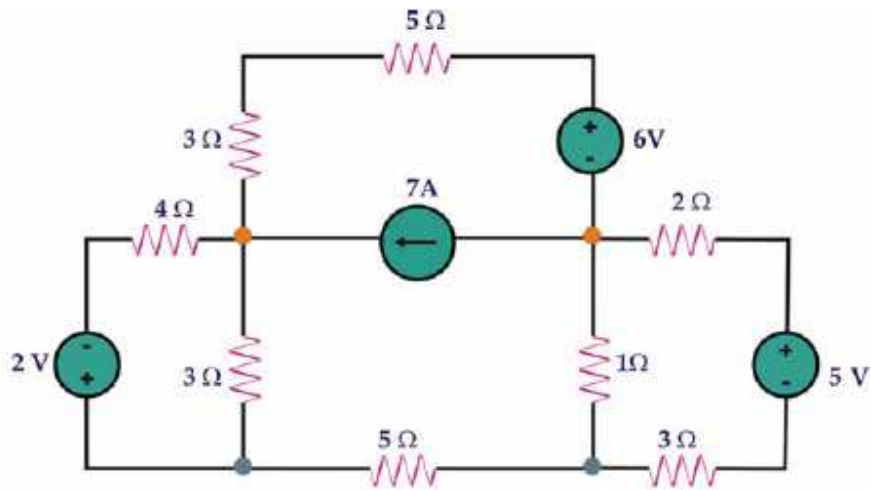

Answer:

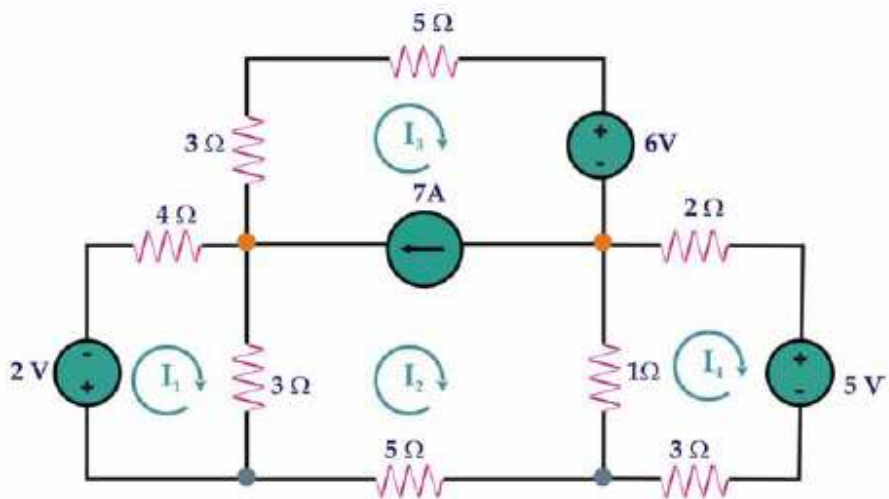

KVL equation for super mesh

$$1(I_2 - I_4) + 8I_3 + 5I_2 + 6 + 3(I_2 - I_1) = 0$$

**PHY301- Circuit Theory Mid Term Solved
With References
| By Masoom Fairy |**

**PHY301- Circuit Theory Mid Term Solved
With References
| By Masoom Fairy |**